

SBSB

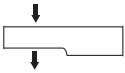

Features

- Single Ended Shear Beam Load Cell
- Stainless Steel
- Easy to Install, Stable & Reliable
- Suitable for Floor Scales, Blending & Mixing Systems, Belt Scales and Package Systems, etc.
- Rated up to IP68
- Hermetically Sealed
- Equivalent to: HBM B35 & HBM H35

Dimensions

Capacity		A	B	C	D	E	M	F	G	H	I	J
1,000 - 5,000 lb	in	5.12	1.18	3.00	1.00	0.50	1/2-20 UNF-2B	1.21	0.53	3x Φ 0.53	1.18	5.6
	mm	130.0	30.0	76.2	25.4	15.7		30.7	13.5	3x Φ 13.5	30.0	142.2

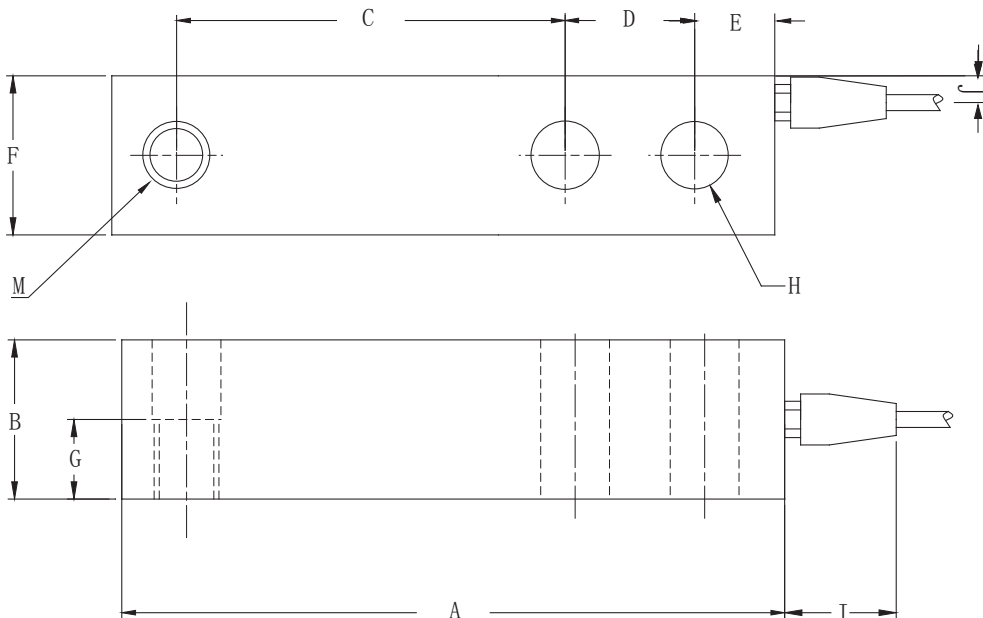

Schematic

Red: + excitation
 Black: - excitation
 Green: + signal
 White: - signal

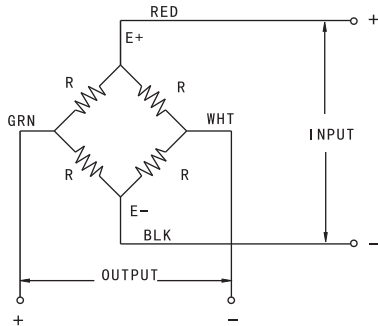

Capacities / Model

1,000 lb	SBSB-1K
2,500 lb	SBSB-2.5K
4,000 lb	SBSB-4K
5,000 lb	SBSB-5K/SE

Specifications

Rated Output	3.0mV/V \pm 0.1%
Zero Balance	\pm 1% of rated output
Creep after 30 minutes	\pm 0.03% of rated output
Nonlinearity	\pm 0.03% of rated output
Hysteresis	\pm 0.03% of rated output
Repeatability	\pm 0.03% of rated output
Temp. effect on output	\leq 0.002% of applied output/ $^{\circ}$ C
Temp. effect on zero	\leq 0.002% of rated output/ $^{\circ}$ C
Safe Temp. Range	-10 $^{\circ}$ C to + 70 $^{\circ}$ C
Temp. Compensated	-10 $^{\circ}$ C to + 50 $^{\circ}$ C
Safe Overload	150%
Input Impedance	387 ohm \pm 5 ohm
Output Impedance	350 ohm \pm 3 ohm
Insulation Resistance	\geq 5000 M ohm (50V DC)
Rated Excitation	10V DC/AC
Maximum Excitation	15V DC/AC
Cable Length	20 ft (6.1 m)
Cable Color Code	Red(+E) Black(-E) Green(+S) White(-S)